

# BARRIER OPTIONS

## Pendulum support and barrier boom support

### Pendulum support

- The pendulum support is used to make maximum use of the passageway
- It is attached to the boom and moves with the boom
- Standard white RAL9010

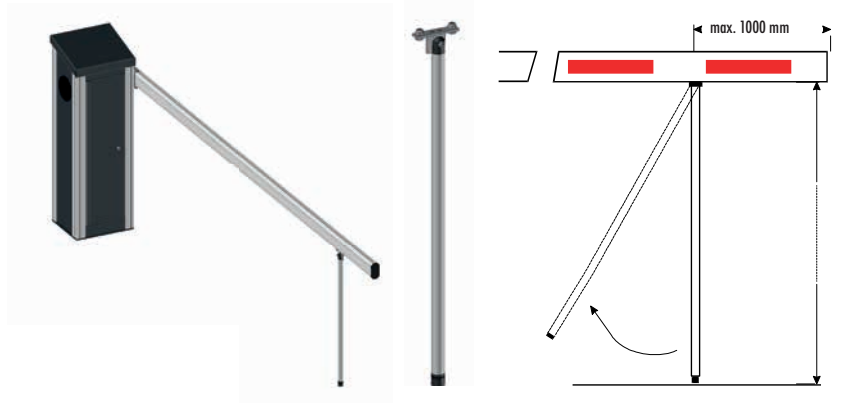

Technical specifications	
<b>Support</b>	Aluminum - RAL9010 - 2,5 mm thick
<b>Dimensions</b>	Diameter 30 mm
<b>Base</b>	Rubber base and an o-ring
<b>Mechanism</b>	Hinge mechanism
<b>Mounting</b>	To the counter plate of the barrier boom
<b>Type barrier arms</b>	Octagonal and round
<b>Height</b>	Adjustable
<b>Warranty</b>	2 years
<b>Article number</b>	1-010100-0050-000-910-00

### Barrier boom support

- The barrier boom support serves as support and damping when the barrier boom arm comes into a horizontal position.
- Standard white RAL9010

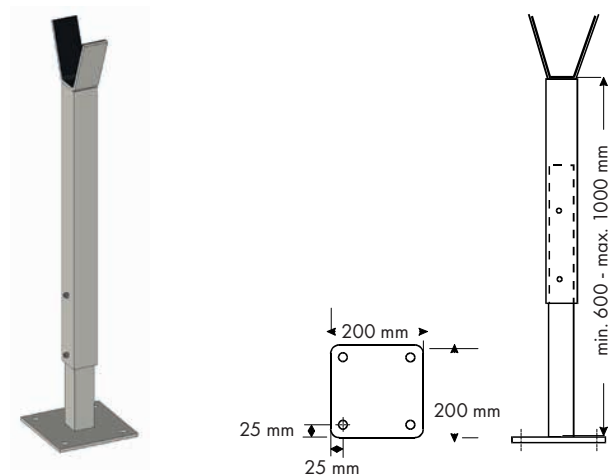

Technical specifications	
<b>Profiles</b>	Aluminum - powder coating RAL9010 - 4 mm thick
<b>Dimensions profiles</b>	60 x 60 mm - 50 x 50 mm
<b>Adjustable height</b>	Between 600 and 1000 mm
<b>Locking height</b>	2 stainless steel screws
<b>Support fork</b>	Equipped with a 2 mm anti-rattle piece (4)
<b>Base</b>	200 x 200 mm
<b>Warranty</b>	2 years
<b>Article number</b>	1-010100-0024-000-901-00



### Barrier boom support with electromagnet

- A barrier boom support with an electromagnet (24Vdc / 20W) provides an extra locking mechanism for the barrier boom in horizontal position
- Standard white RAL9010
- The magnet is installed onto the support fork
- A highly magnetic counter plate is mounted onto the barrier boom

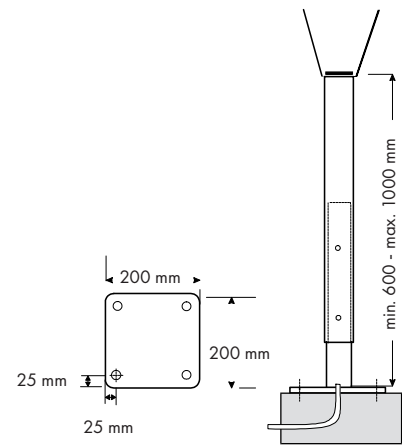
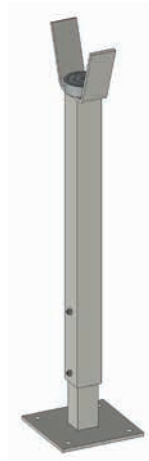

Technical specifications	
<b>Profiles</b>	Aluminum - powder coating RAL9010 - 4 mm thick
<b>Dimensions profiles</b>	60 x 60 mm - 50 x 50 mm
<b>Adjustable height</b>	Between 600 and 1000 mm
<b>Locking height</b>	2 stainless steel screws
<b>Electro-magnet</b>	24 VDC / 20W
<b>Base</b>	200 x 200 mm
<b>Cable</b>	2 x 1,5 mm <sup>2</sup> + earthing
<b>Warranty</b>	2 years
<b>Article number</b>	1-010100-0025-000-901-00

### Extended barrier boom support

- This barrier support is perfectly suited for places with lots of wind turbulence
- Standard white RAL9010

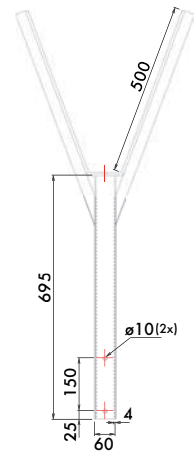

Technical specifications	
<b>Profiles</b>	Aluminum - powder coating RAL9010 - 4 mm thick
<b>Dimensions profiles</b>	60 x 60 mm - 50 x 50 mm
<b>Adjustable height</b>	Between 600 and 1000 mm
<b>Locking height</b>	2 stainless steel screws
<b>Support fork</b>	Equipped with a 2 mm anti-rattle piece (4)
<b>Base</b>	200 x 200 mm
<b>Warranty</b>	2 years
<b>Article number</b>	1-010100-0039-000-901-00